



## IBIS in Applications

- Modeling Complex IO with IBIS

IBIS-JEITA Joint Meeting  
March 24, 2005, Tokyo, Japan  
Lance Wang

1 CADENCE DESIGN SYSTEMS, INC.



## Outlines

- Device Models in EDA Tools
- New Challenges and New Studies
- An Applicable Solution - Macromodeling
- An Industrial Macromodeling Example

2

## Outlines

- Device Models in EDA Tools
  - Transistor Level Models
  - Behavioral Models
  - How EDA tools use Behavioral Models
- New Challenges and New Data
- An Applicable Solution – Macromodeling
- An Industrial Macromodeling Example

3

## Device Models

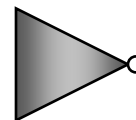
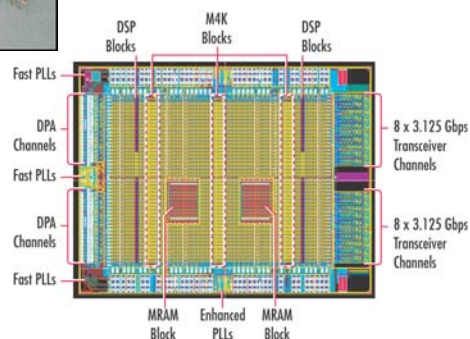
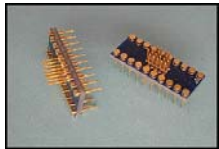

4

## Spice Transistor Level Models

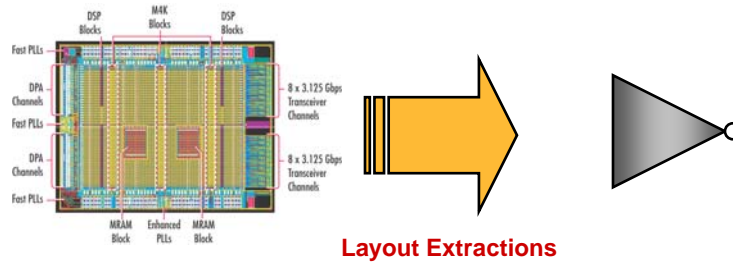

- Very Complicated
- A lots of unusable stuff
- Too slow in the simulations

5

## Behavioral Models

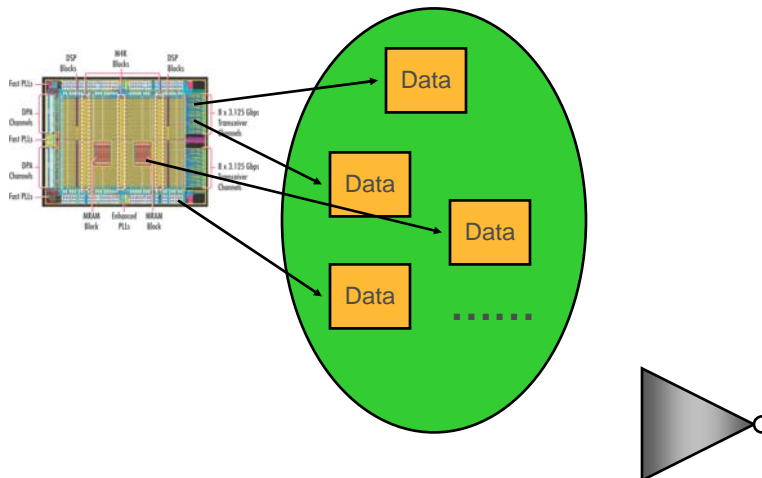

6

## Behavioral Model



## IBIS model

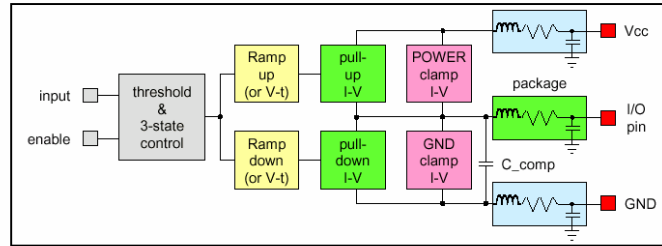

Block diagram of CMOS buffer

### A basic IBIS model consists of:

- four I-V curves: - pullup & POWER clamp
- pulldown & GND clamp
- two ramps: - dV/dt\_rise
- dV/dt\_fall
- die capacitance: - C\_comp
- packaging: - RLC values

for each buffer on a chip

7

## IBIS Model Vendors



### Top10 IBIS Model Vendors on Web

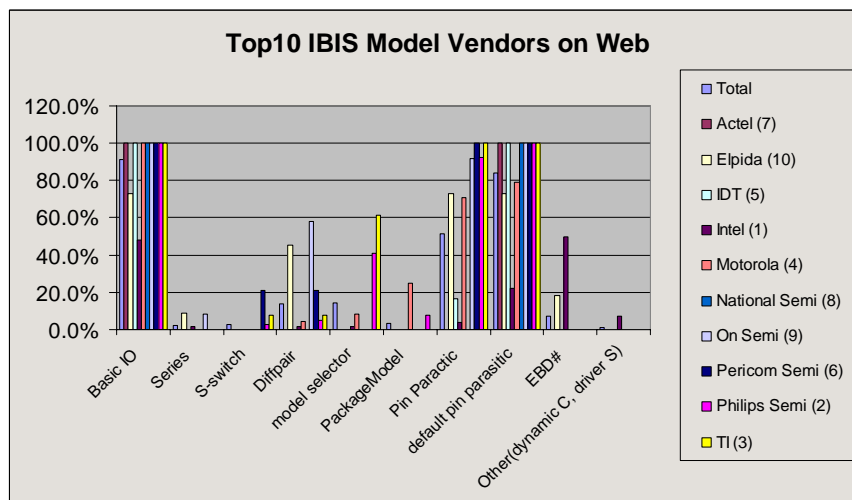

8

## IBIS in EDA Tools



- Major EDA Simulators are supporting IBIS now

- Cadence

- Mentor

- Synopsys

- Zuken

- Agilent

SPICE Simulators are taking IBIS now !!!

And many, many more .....

9

## IBIS in EDA Tools



- Behavioral data in Spice simulators

$$I(\text{pad}) = I_{pd}(V(\text{pad})-V(\text{gnd})) * W_d(t) + I_{cd}(V(\text{pad})-V(\text{gnd\_c}))$$

$$+ I_{pu}(V(\text{pad})-V(\text{pwr})) * W_u(t) + I_{cu}(V(\text{pad})-V(\text{pwr\_c}))$$

- Results are accurate
- Much, much faster simulation time
- IP Protected

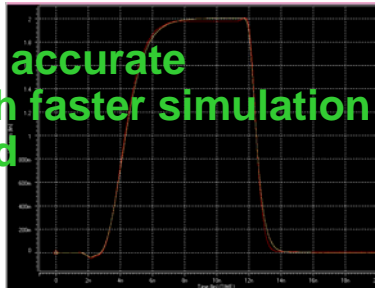

HSpice Transistor Model vs. IBIS Model

10

## Support Advance IBIS Features



- Driver Schedule
- Series / Series Switch (FET)
- Submodel (Dynamic Clamps, Bus Hold ...)
- Differential Pair
- EBD (Board Models)
- ICM (Interconnect Models)
- More .....

11

## IBIS Implementation - Driver Schedule



[Driver Schedule]				
Model_name	Rise_on_dly	Rise_off_dly	Fall_on_dly	Fall_off_dly
driver1	0.0ns	NA	0.0ns	NA
driver2	NA	0.666ns	NA	0.666ns

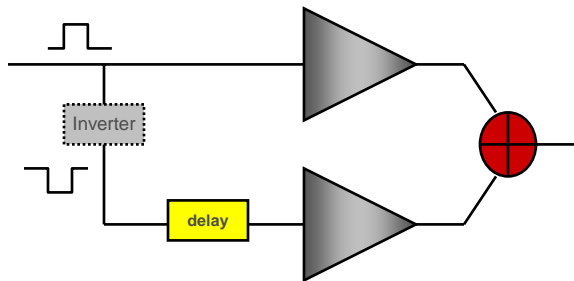

12

## IBIS Implementation - Differential Pair Driver

cadence

[Diff Pin]	inv_pin	vdiff	tdelay .....
1	2	0	1ns
[Series Pin Mapping]	pin_2	model_name .....	
1	2	Series1	

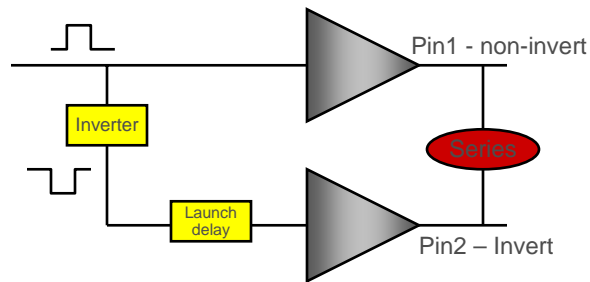

13

## Outlines

cadence

- Device Models in EDA Tools
- New Challenges and New Data
  - Complex-IO Devices
  - New Data from Survey
- An Applicable Solution – Macromodeling
- An Industrial Macromodeling Example

14

# Then ..... New Challenges

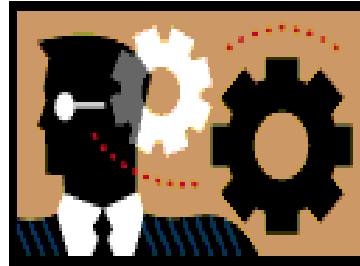

15

# Complex-IO Devices

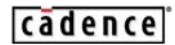

## Pre-emphasis/De-emphasis

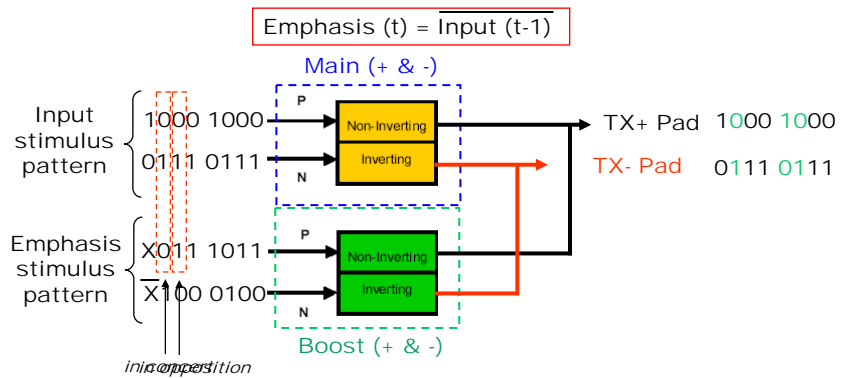

Picture from Michael Mirmak's presentation in DesignCon East IBIS Summit 2004

16

## Complex-IO Devices



### Self calibrating driver

(Calibrating Output Impedance only)

(For DDR2, when controller in a read cycle, the receiver is terminate )  
(50 ohms. The resistor also requires to calibrate at run-time)

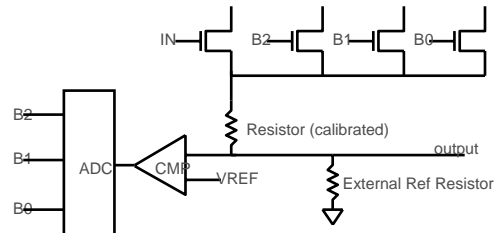

Note:  
1) PMOS side is not being shown here.

17

## Complex-IO Devices



### Driver with Slew Rate Control

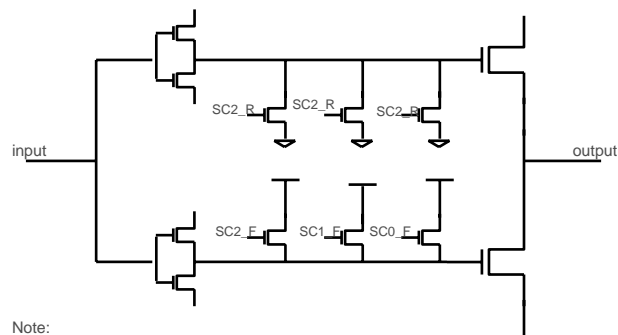

Note:  
1) For simplicity, Nmos and Pmos are used interchangeable.  
2) Independent slew control for Rise and Fall.

18

## Complex-IO Devices



And More to Come ... ..

*As Always for Technologies!!!*

Where is IBIS?

---

19

## The Original “Box”



- 1<sup>st</sup> PCI Chipset  
(33 MHz)

**IBIS**

- 1<sup>st</sup> Pentium uP  
(66 MHz)

---

20

## ...and the "Box" did grow

cadence

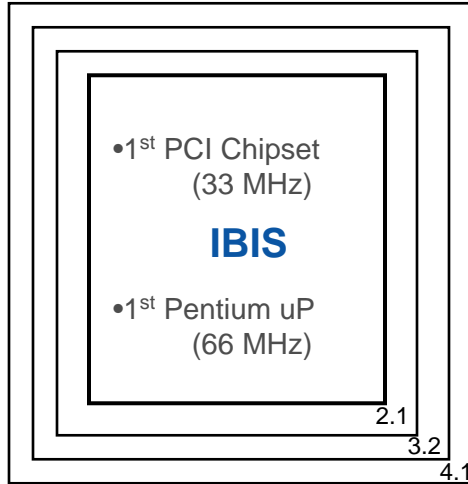

*An increasing  
amount of Complex  
IO models are  
missing the box*

21

## Our Mission

cadence

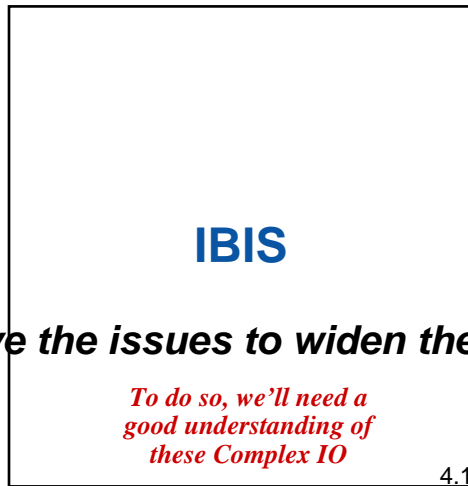

22

## The Current Situation

cadence™

IBIS

*What is the format of most  
of the red dots today?*

4.1

23

## 11 Interviews During December 2004

cadence™

- All are involved with Complex IO
  - Majority were not CDS users
- Good re-introduction to the issues
- The issues are many
  - and the solutions weren't clear
- Will use this data to propose solutions
- Most want "industry standard solution"
  - but don't know how to get there
- So who will lead?



24

## High-Speed PCB Web Surveys



- 64% say that more than 20% of the models they receive are Hspice

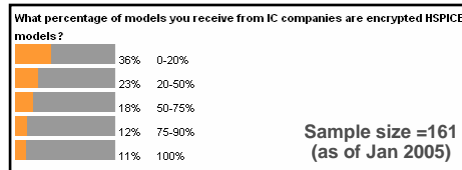

<http://www.pcbhighspeed.com/discuss/user/non-frames/surveyresults.asp?surveyid=62>

- 69% say that this percentage increased in 2004 over 2003

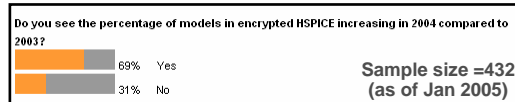

<http://www.pcbhighspeed.com/discuss/user/non-frames/surveyresults.asp?surveyid=63>

25

## HSpice Related Interview Questions



- “Do you want to see [External Model] HSpice?” - all “yes”
  - Half qualified this as a non-optimal short-term solution

*This is actually already happening*

- “Do you see HSpice as a long-term solution?” - all “no”
  - Unanimous reason: “it’s too slow”
- As such, also unanimous in need to return to behavioral

26

## What has Happened

cadence

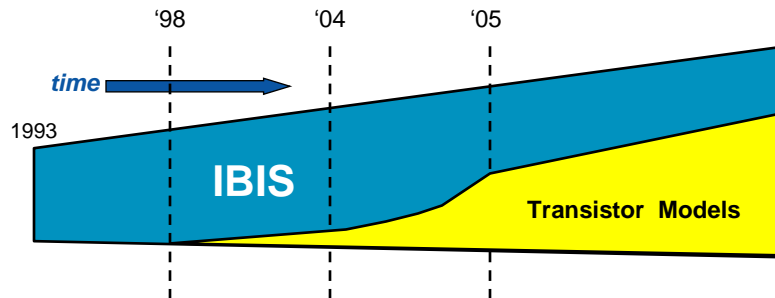

- IBIS enjoyed 5 years as THE digital IO model format
- Higher frequencies brought new issues and more skeptics
- Gigabit serial links brought rapid transistor model increase in 2004

27

## What Must Happen

cadence

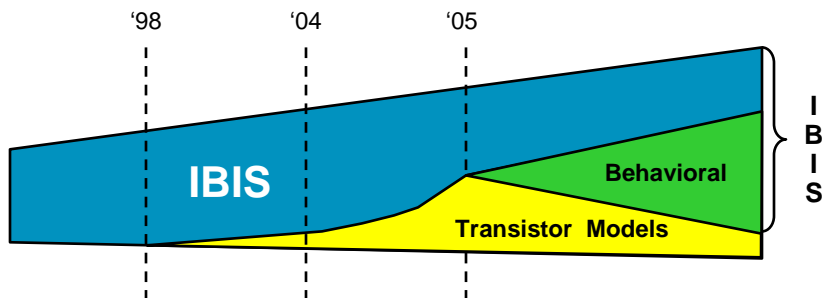

- Enable faster behavioral solutions

28

## Features of Behavioral Solution



1. Fast
2. Protects IP
3. Template based
4. Works in many tools
5. Have links to IC design

*What behavioral options exist?*

29

## AMS Models – the Positives



- Most interviewed at this point are unfamiliar with AMS
  - When asked if they think AMS can be a good solution:
    - 3 said “yes”, 3 were hopeful, and 4 were unsure, 1 said no
- The experts list the following positives
  - Standards with documented specs
  - Mathematical freedom
  - Conditionals
  - File IO
  - Flexible language

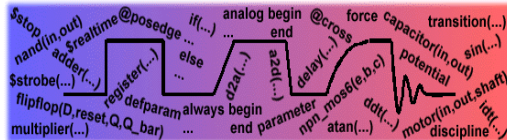

30

## AMS Models – Issues to Solve



- Unfamiliar in SI world, learning curve exists
  - Must seed with templates / training
- Spec nuances/implementations (as with IBIS)
- Not naturally occurring in IO design
  - This is why transistor-level models get used
- IP protection
  - 3 would encrypt, 2 might, 4 are unsure, 2 would not



## Any other solutions?

31

## Outlines



- Device Models in EDA Tools
- New Challenges and New Data
- An Applicable Solution – Macromodeling
  - What is Macromodeling and Why
  - Our Experiences
- An Industrial Macromodeling Example

32

## What is MacroModeling and Why?

cadence

**KEY Conclusions**

**Equation-based macromodeling of LVDS drivers**

- ❖ **Flexible methodology**
  - no specific assumption on device internal structure (**preserve IP**)
  - handle drivers with enhanced features (e.g., **control ckts**)
- ❖ **Accurate and efficient** macromodel (**5+10x speed-up**)
- ❖ Straightforward **SPICE, VHDL-AMS** implementations
- ❖ Ready **available also for EDA SI tools** via the **IBIS** multilingual extension

**Methodology only**

**In progress: modeling of LVDS drivers with pre-emphasis**

**AMS needs Macromodeling Methodology too !!!**

SPI 2004 SPI 2004 17 EMC group

33

## What Our Experience has Shown

cadence

- Spice Macromodeling is everywhere
- Cadence has always had SPICE macromodeling
  - And this has made IBIS keywords support quite simple
- Once we had a central IBIS 2.1 driver element

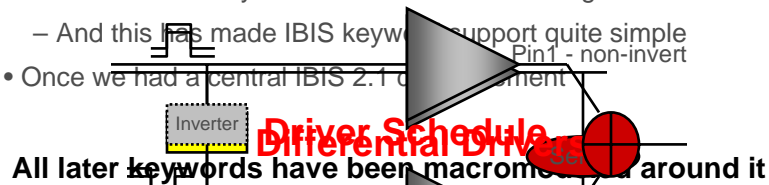

**All later keywords have been macromodeled around it**

- In other words, basic SPICE around a B driver element has handled everything IBIS has added for the last 10+ years
- Template is another **KEY** for Complex-IO Modeling

34

## Macromodel from architecture templates

- Most modern devices are based on known DSP circuit architectures

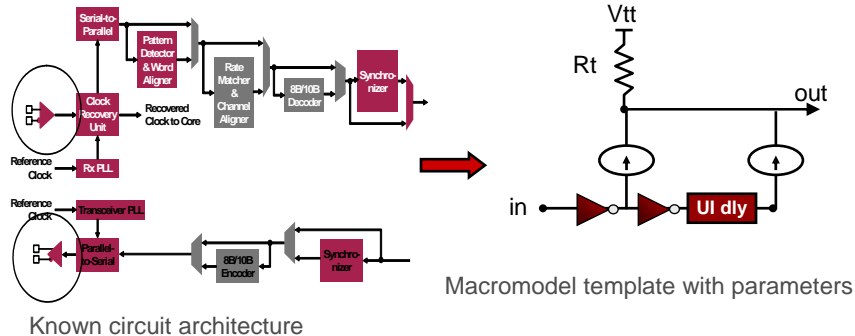

35

## Behavioral SPICE Solutions

- 2.5 Gbps PCIe SerDes Chipset
  - [http://www.cadence.com/company/newsroom/press\\_releases/pr.aspx?xml=090804\\_intel](http://www.cadence.com/company/newsroom/press_releases/pr.aspx?xml=090804_intel)
- 1.5 Gbps S-ATA SerDes
  - <http://www.designcon.com/conference/74133.html>
- Differential pass-thru receiver
  - <http://www.cadence.com/pub/cis/whitepapers/jan00/telian.zip>
- Adjustable FPGA SerDes
  - [http://www.altera.com/corporate/newsroom/releases/releases\\_archive/2004/products/nr-cadence\\_design\\_kit.html](http://www.altera.com/corporate/newsroom/releases/releases_archive/2004/products/nr-cadence_design_kit.html)
- Front-side bus driver, impedance control, SSN, & gate choke effect
  - [http://www.cadence.com/company/newsroom/press\\_releases/11\\_16\\_98\\_SQ\\_Intel\\_Merced\\_Processor.doc](http://www.cadence.com/company/newsroom/press_releases/11_16_98_SQ_Intel_Merced_Processor.doc)
- Others under NDA, mostly higher speed SerDes

36

*The technique has been used for many "beyond IBIS" Complex IO models*

## SPICE Macromodeling



- Many tools and users have experience with it
- With template help, model makers are succeeding
- Academia is quite engaged in macromodeling research

- [http://domino.research.ibm.com/acas/w3www\\_acas.nsf/images/proposals\\_04.05/\\$FILE/madhavan.pdf](http://domino.research.ibm.com/acas/w3www_acas.nsf/images/proposals_04.05/$FILE/madhavan.pdf)
- [http://domino.research.ibm.com/acas/w3www\\_acas.nsf/images/projects\\_03.04/\\$FILE/canavero.pdf](http://domino.research.ibm.com/acas/w3www_acas.nsf/images/projects_03.04/$FILE/canavero.pdf)
- [http://www.spi.uni-hannover.de/2004/presentations/spi04\\_s08\\_p02\\_Stievano.pdf](http://www.spi.uni-hannover.de/2004/presentations/spi04_s08_p02_Stievano.pdf)
- [http://www.ece.ncsu.edu/erl/html2/papers/paulf/2003/paulf\\_2003\\_10\\_varma.pdf](http://www.ece.ncsu.edu/erl/html2/papers/paulf/2003/paulf_2003_10_varma.pdf) ... etc.

---

37

## Outlines



- Device Models in EDA Tools
- New Challenges and New Data
- An Applicable Solution – Macromodeling
- An Industrial Macromodeling Examples

---

38

## Industry example- Altera Stratix GX



“Altera successfully adapted the MacroModel templates to produce fast and accurate models of our multi-gigabit transceivers. Not only did the resulting model correlate well, it also simulates between 20 to 400 times faster than its transistor-level counterpart. And the model can be easily adjusted to match the behaviors of actual silicon measured in the lab.”

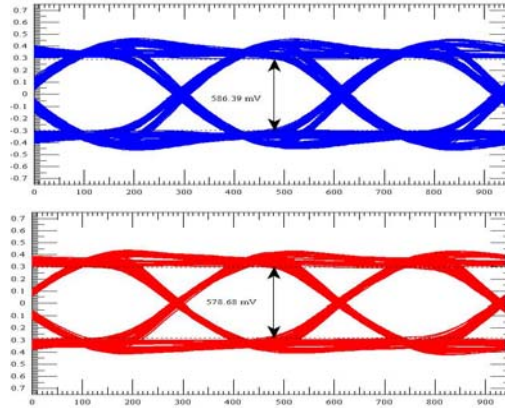

Correlation: MacroModel vs TransistorModel

“Overall, the templates were simple to work with and very valuable amidst the challenges of multi-gigahertz design.”

39

## Correlation - Altera Stratix GX



SQ signal explorer expert: tx\_rx\_example.top 1.0 Project: C:\...TX\_Correlation

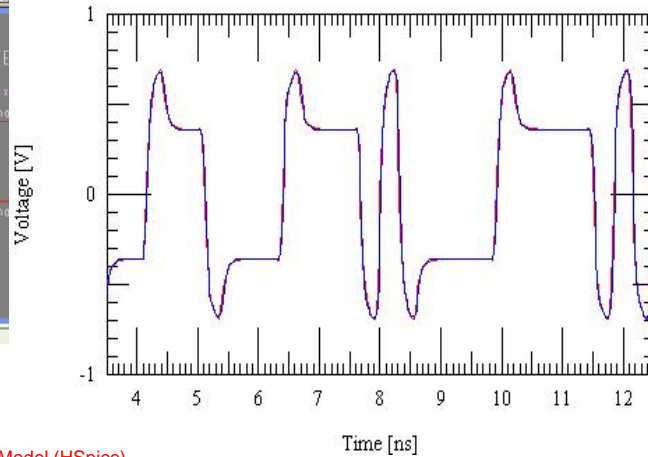
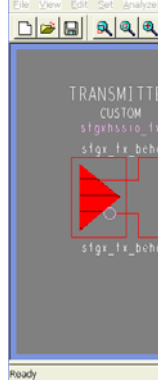

- Transistor Level Model (HSpice)
- Spice Macromodel (Cadence DML)

Transmitter output at factor=5

40

And, the latest news



- Driver Schedule in IBIS for 4 tap pre-emphasis buffer is working

```
(DS_4TAP_4tap
[Model] 4tap
Model_type Oper
| (Threshold
| (maximum 1.2
| (minimum 1.2
| (typical 1.2
Umeas = 1.2
Uref = 1.5
Pref = 50
Cref = 0.0
| (MacroModel
| (NumberOfTerm
| (Parameters
| (Buffers
| (DS_4TAP_4t
| (T001_BUFF
| (T002_BUFF
| (T003_BUFF
| (T004_BUFF
| (Voltage Range)
| (Temperature Range)
| (MinTupMaxPa
| (MTHSUBCKT
| (ftotype P
| (maximum m
| (minimum m
| (typical t
| for: http://www.ec
| Note that on_dly
| Model_name
| +DS_4TAP_4tap_BUF
| +T001_BUFF+TBD
| +T002_BUFF+TBD
| +T003_BUFF+TBD
| +T004_BUFF+TBD
| +MTHSUBCKT+typica
main
tap2
tap3
tap4
| * Sources for ena
| von ON 0 1
| uoff OFF 0 0
|
| ***** The main bdrur.
| * Output drive is
| bdrur_DS_4TAP_4ta
```

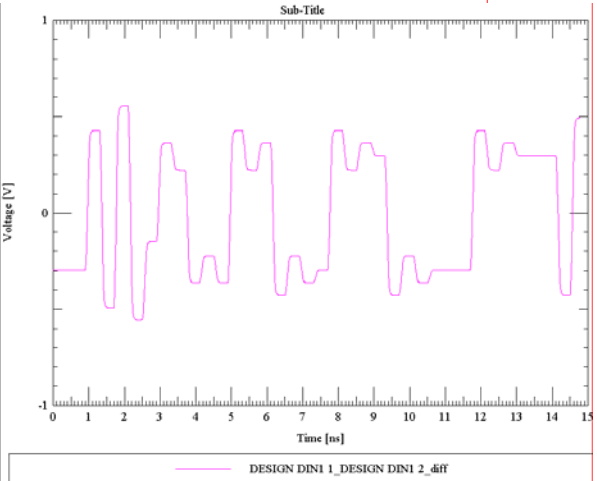

41



Thank You

謝謝

