

# Proper IBIS Package Modeling Techniques and Usage in Ideal PDS and SSO Simulations

Sam Chitwood  
FAE Manager

IBIS Summit  
February 7, 2008

# Outline

- Assumptions in IBIS Package Models
- The [Pin] Model
  - Inherent limitations and their implications
  - Extraction techniques for Ideal-PDS applications
- The [Define Package Model]
  - What a difference coupling can make...
  - Extraction techniques for SSO applications
- PDS Connectivity at the Die (and Board)
- IBIS Pkg Model Accuracy – How high can we go?
- Summary
- Acknowledgements and References

## Assumptions in IBIS Package Models

- 1:1 relationship between die pads and board pins
  - No signal net branching is allowed
  - Multiple die not supported
  - Also applies to POWER and GND nets
- RLCs are allowed for POWER and GND pins
- [Pin Mapping] connects PU, PD, and clamps to actual POWER and GND locations
  - Should be used in realistic PDS situations
  - Generally agreed that these links are at the die side
  - This connection is “ideal” (no die parasitics assumed)
  - Multiple physical die pads can become one logical circuit terminal in simulation
- *This document’s modeling techniques assume package POWER and GND nets have multiple die pads, board pins, and “plane” routing.*

# The [Pin] List and Package Model

- Associates I/O models to pins and signal names.
- Should list **ALL** board pins! Unfortunately POWER and GND pins are sometimes omitted.
- R\_pin, L\_pin, and C\_pin are allowed for all pins.
- No mechanism to include coupling (mutual terms).

View Model Selection

- SPICE T-model
- SPICE Pi-model
- IBIS .pkg model
- Pin model: IBIS format
- Pin model: Excel format
- DC Resistance

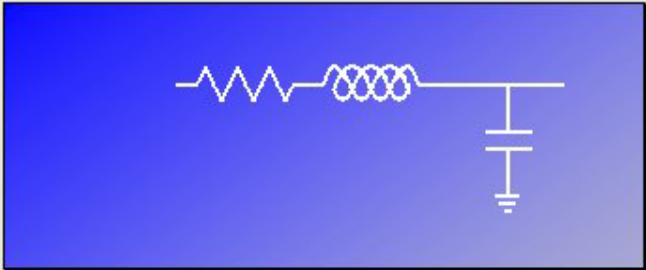

BGA1-W4	Net_11	signal	0.24663	6.156e-9	1.23e-12
BGA1-V4	Net_12	signal	0.24498	5.994e-9	1.213e-12
BGA1-U4	Net_13	signal	0.24075	5.893e-9	1.204e-12
BGA1-T4	Net_14	signal	0.23767	5.756e-9	1.178e-12
BGA1-R4	Net_15	signal	0.23221	5.625e-9	1.153e-12
BGA1-P4	Net_16	signal	0.23828	5.626e-9	1.178e-12



# Limitations of [Pin] for PDS Modeling

- PDS nets do not have a 1:1 pad-pin ratio.
- Because the [Pin] model does not allow coupling between PDS pins, an accurate per-pin PDS [Pin] model is virtually impossible to construct (see references).
- If RLCs for POWER and GND pins are present, how should they be interpreted? These partials have no mutuals to relate them, thus no loops can be inferred.
- What does your ideal-PDS PCB SI tool do with the GND and “global ground” nodes shown in the figure?
- What does the GND pin capacitance represent? You cannot measure this.
- Therefore, the [Pin] package model should be extracted for one application only:

**Ideal PDS simulations**

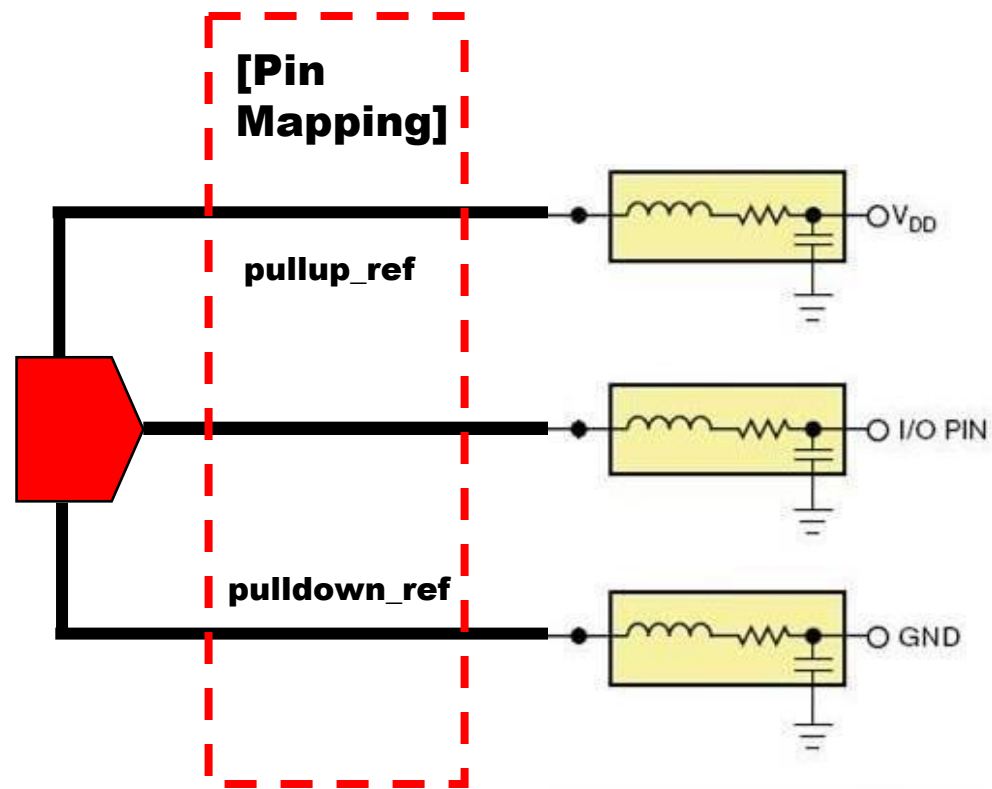
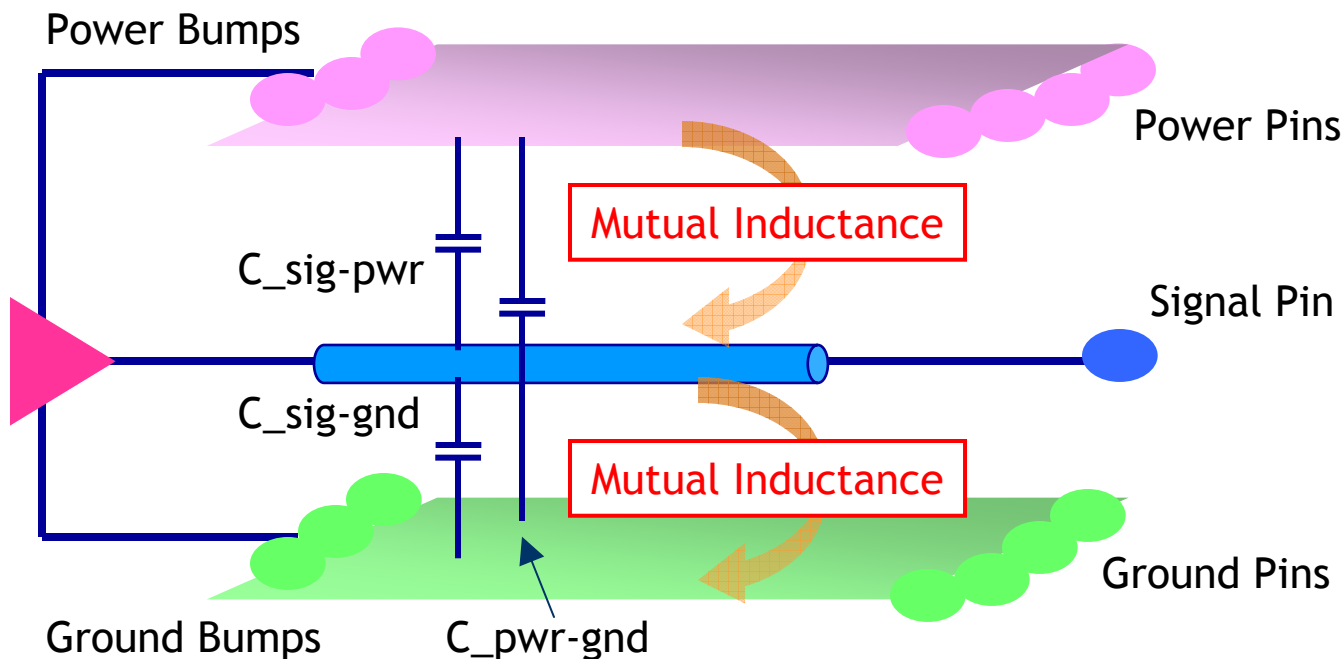

Fig 1. An incorrect [Pin] model containing per-pin POWER and GND RLC entries.

Unfortunately the [Pin] example in the IBIS spec encourages this practice and many IBIS users expect to see these entries.

# Limitations of [Pin] for Signal Modeling

## Package Geometry (Simplified)



- Signal  $C_{pin}$  has the **exact same problem** that  $C_{comp}$  has in realistic PDS simulations! For an accurate description, we must know the split between  $C_{sig-pwr}$  and  $C_{sig-gnd}$ .
- Since no mutual inductance can exist between signal and POWER or GND pins, signal return paths cannot be inferred from the model. Return current could be on POWER, GND, or both.
- Is  $R_{pin}$  at DC or x MHz to consider skin effect? How to handle the return path's impact?

# [Pin] Inductance and Resistance Extraction

## Package Geometry (Simplified)

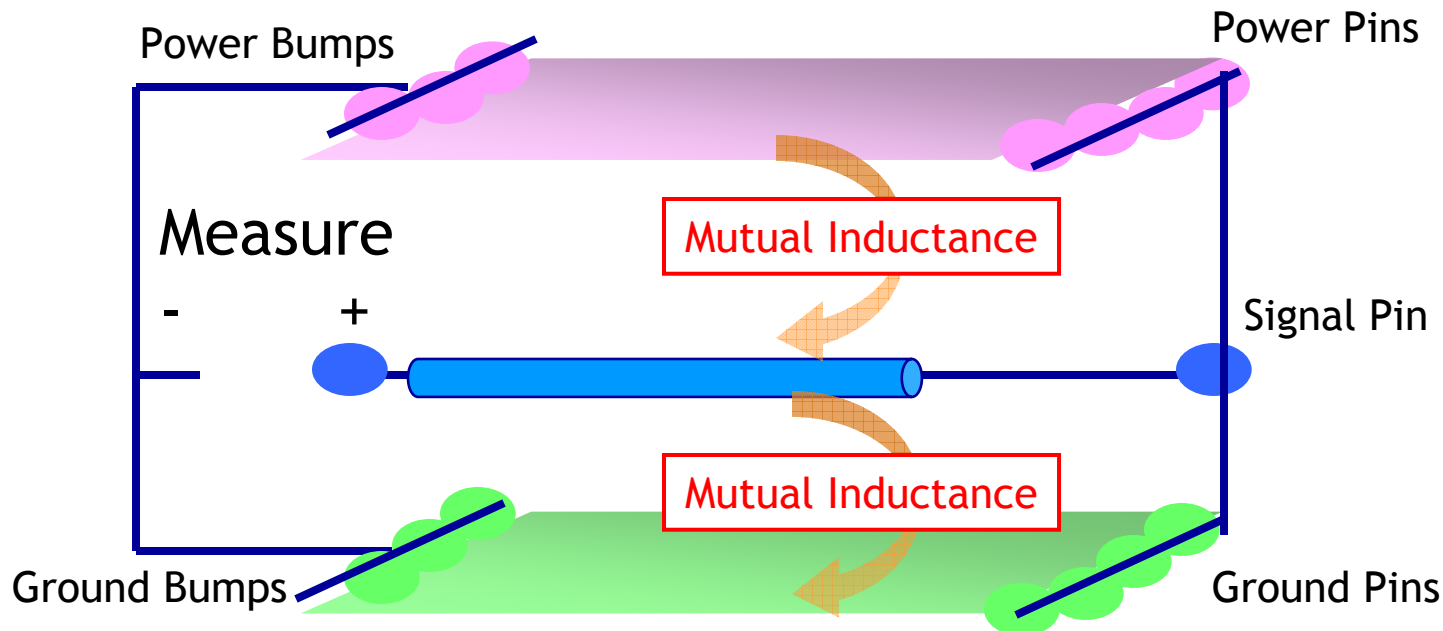

- Making the assumption that the [Pin] model will be used in ideal-PDS simulations solves many of the problems with this model. *No RLCs should be present in POWER or GND pins.*
- Signal pin inductance is now  $L_{loop}$ . It assumes all POWER and GND nets are AC-shortcd at the pad and pin sides (as they will be in their intended ideal-PDS SI simulations).
- Signal pin resistance is also  $R_{loop}$ . There is no “correct” frequency for extraction.

# [Pin] Model Capacitance Extraction

## Package Geometry (Simplified)

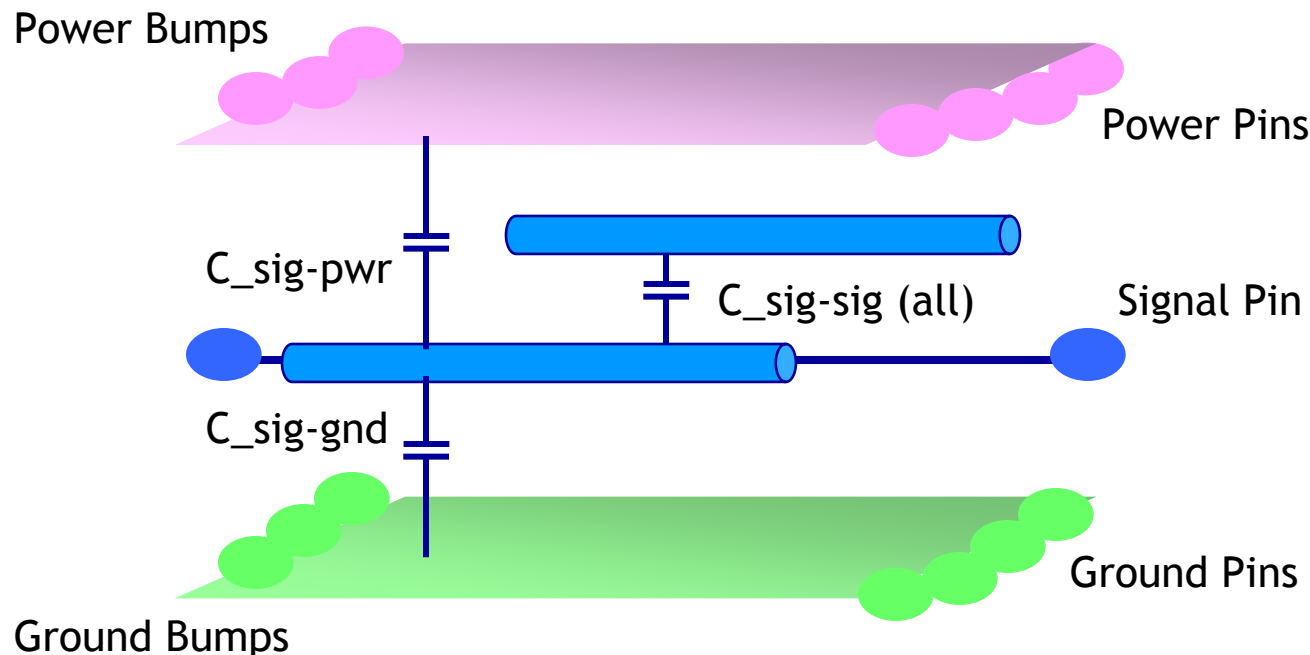

- Signal pin capacitance is now  $C_{\text{total}} = C_{\text{sig-pwr}} + C_{\text{sig-gnd}} + C_{\text{sig-sig (all)}}$ .
- This model assumes all POWER and GND nets are AC-shortcd at the pad and pin sides (as they will be in their intended ideal-PDS SI simulations).
- $C_{\text{sig-sig (all)}}$  is usually much smaller than  $C_{\text{sig-pwr}} + C_{\text{sig-gnd}}$ , but should be included under the assumption that neighboring nets are held quiet high or low.

# Correct Usage of the [Pin] Model

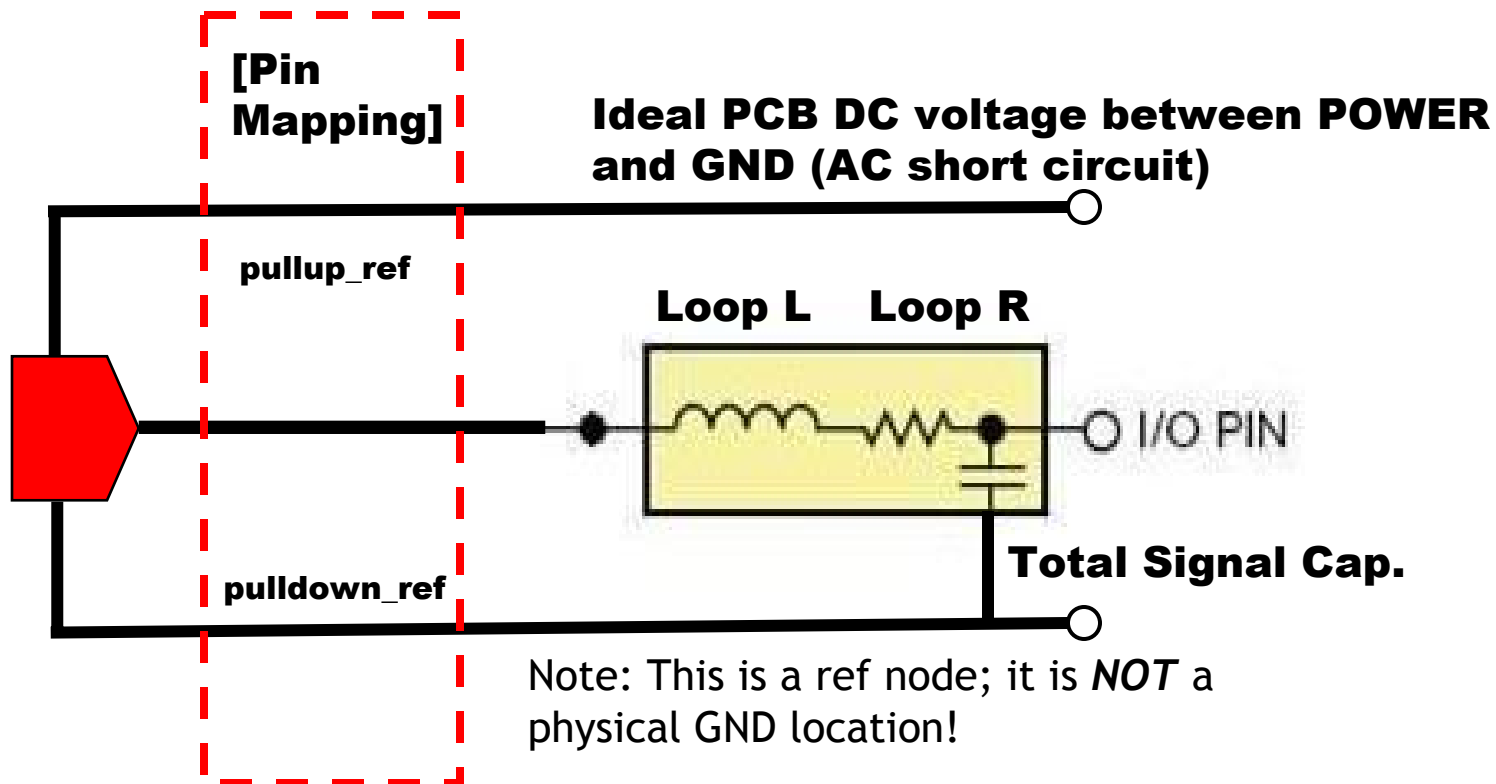

- This [Pin] model implementation allows simple connection of driver, receiver, and PCB models.
- The pulldown node becomes a “ref” node and makes voltage measurement easy.
- These package values are physical quantities that can be measured and correlated.
- [Pin Mapping] is shown for completeness, but its use is irrelevant in this situation.

# A note about [Package]

- Intended to quickly identify the numerical min. and max. RLC values of the [Pin] list
- If POWER & GND RLCs are in the [Pin] list, [Package] should consider these values
- Not recommended for any simulation unless no other model is available

View Model Selection

SPICE T-model

SPICE Pi-model

IBIS .pkg model

Pin model: IBIS format

Pin model: Excel format

DC Resistance

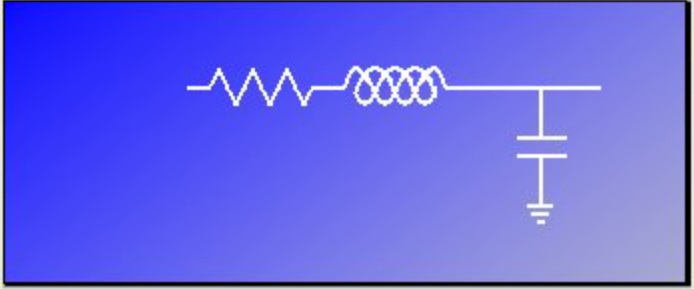

[Package]					
	typ	min	max		
R_pkg	0.26601	0.2316	0.31298		
L_pkg	6.487e-9	5.563e-9	7.586e-9		
C_pkg	1.302e-12	1.152e-12	1.511e-12		
[Pin]					
	Signal_name	model_name	R_pin	L_pin	C_pin
BGA1-P1	VDD_1	POWER			
BGA1-F1	VDD_1	POWER			
BGA1-B1	VDD_1	POWER			
BGA1-U1	VDD_1	POWER			

# The [Define Package Model]

- Typically delivered in a separate .pkg file
  - Facilitates separate I/O and pkg modeling efforts
- Two types: [Number of Sections] and [Model Data]
- [Number of Sections] technique essentially makes the same assumptions as [Pin] models
  - No coupling allowed > for ideal-PDS simulations only
  - L and R are loop values, C is total
  - Fork option allows modeling of package stubs
- [Model Data] utilizes R, L, and C matrices
  - Coupling (mutuals) can finally be defined between pins!
  - Sparse matrices can be used to simplify model complexity
  - Ensure model passivity if coupling terms are removed

# [Model Data] Extraction Methodology

- Although matrix coupling facilitates per-pin PDS modeling, it is not generally recommended because:
  - The 1:1 pad-pin ratio is still (incorrectly) assumed
  - The number of coupling terms would be excessively large
  - Mutual resistance terms are not supported in some tools
- The PDS model extraction should lump all POWER net pins on a per-net basis
  - For example, if VDD5 has 5 pins it should only have 1 logical pin in the [Model Data] pin list
- Pick one GND reference net that will NOT appear in the list of [Model Data] pins
  - This net will become the “ref” node of the final circuit
  - All L and R values in the matrix are loop WRT this net
  - Diagonal capacitance matrix terms are  $C_{\text{net-GND}}$ .

# [Model Data] Extraction Methodology

Assume **16 signal nets** of the package are of interest for simplicity of discussion. The PDS nets will also be modeled, including all necessary coupling terms.

## Top of Package:

- All **POWER pins** are **lumped** as a positive node.
- All **GND pins** are **lumped** as a negative (or reference) node.
- Port 1** is defined between the positive node and the reference node.
- Ports 2 ~ 17** are defined between corresponding signal pins and the reference node, which is the ground of the package.

Package Top

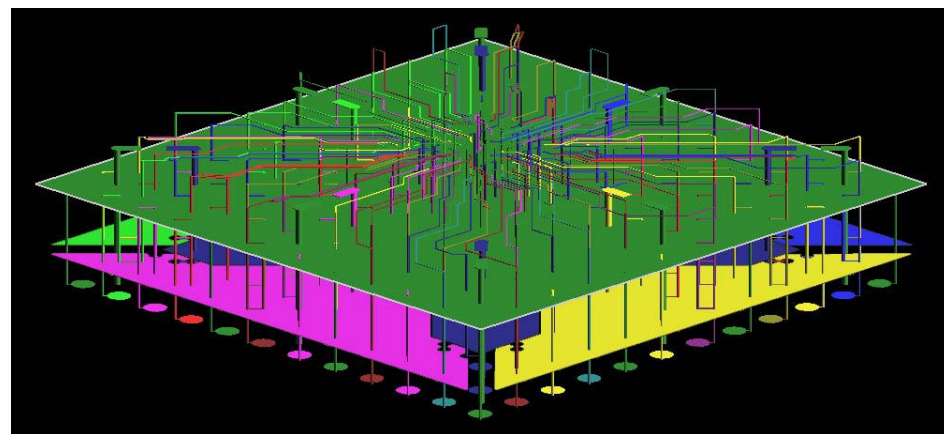
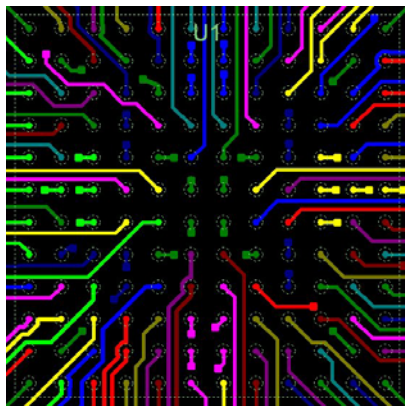

Package Bottom

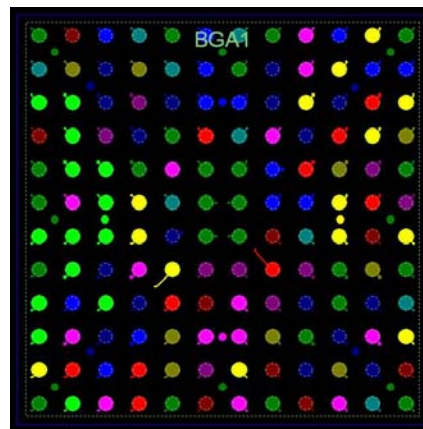

## Bottom of Package:

- All **POWER pins** are **lumped** as a positive node.
- All **GND pins** are **lumped** as a reference node.
- Port 18** is defined between the positive node and the reference node.
- Ports 19 ~ 34** are defined between corresponding signal pins and the reference node, which is the ground of the package.

# Example Pin List Using Lumped Pins

- Net VDD\_1 has multiple pins, but only pin BGA1\_P1 is listed. The same concept applies for net VDD\_2.
- The package has more than 105 physical pins, but this is the number of logical circuit terminals.
- The GND net will not have an explicit pin in the list.

View Model Selection

- SPICE T-model
- SPICE Pi-model
- IBIS .pkg model
- Pin model: IBIS format
- Pin model: Excel format
- DC Resistance

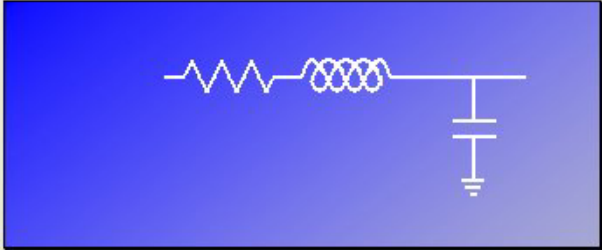

```

|
[Define Package Model]  ibis_wirebond
[Manufacturer]         name 1
[OEM]                  name 2
[Description]          105-pin Package
|
|[Number of Sections]  1
|[Number of Pins]     105
|
|[Pin Numbers]
|[Pin Name]  Net Number  Net Name  Net's All Pins
BGA1-P1      | 1        VDD_1    BGA1-P1
|            |         |         |BGA1-F1
|            |         |         |BGA1-B1
|            |         |         |BGA1-U1
|            |         |         |BGA1-AG1
|            |         |         |BGA1-D1
|            |         |         |BGA1-H1
|            |         |         |BGA1-K1
|            |         |         |BGA1-R1
|            |         |         |BGA1-W1
|            |         |         |BGA1-M1
|            |         |         |BGA1-AC1
|            |         |         |BGA1-AE1
|            |         |         |BGA1-AA1
BGA1-A6      | 2        VDD_2    BGA1-A6
|            |         |         |BGA1-A10
|            |         |         |BGA1-A12
|            |         |         |BGA1-A15
|            |         |         |BGA1-A17
    
```

# Correct Usage of [Model Data]

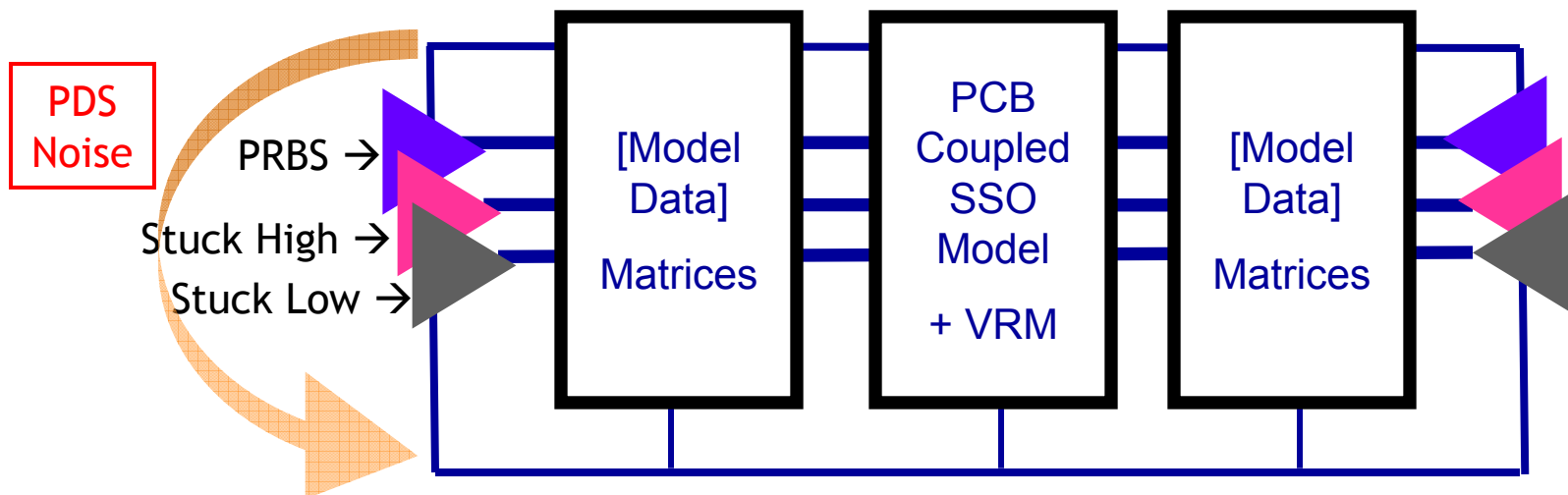

Note: This is a ref node; it is **NOT** a physical GND location!

- This [Model Data] example shows the connections of driver, receiver, and PCB models.
- The pulldown node becomes the “ref” node and makes voltage measurement easy.
- The package values are physical quantities that can be measured and correlated.
- [Pin Mapping] must be used to make the PU, PD, and clamp connections to the logical POWER terminal and the “ref” node (GND net). The EDA tool must support this technique.

# Connectivity at the Die: [Pin Mapping]

Pin Editor : U17 / I80386S-1\_

I80386S-1.ibs Component : [ ]

Pin	Linkage	Pulldown	Pullup	Signal name	Model	Polarity	Stimulus	Enable
1	<input checked="" type="checkbox"/> 1 <==> Node181!!1::D0	GNDGRP0	PWRGRP0	D<0>	Z372091_BI7	Non-Inverting	Stuck_High	Output
100	<input checked="" type="checkbox"/> 100 <==> Node174!!100::D1	GNDGRP0	PWRGRP0	D<1>	Z372091_BI7	Non-Inverting	Stuck_Low	Output
99	<input checked="" type="checkbox"/> 99 <==> Node173!!99::D2	GNDGRP0	PWRGRP0	D<2>	Z372091_BI7	Non-Inverting	V_in_1	Output
96	<input checked="" type="checkbox"/> 96 <==> Node172!!96::D3	GNDGRP0	PWRGRP0	D<3>	Z372091_BI7	Non-Inverting	V_in_1	Output
95	<input checked="" type="checkbox"/> 95 <==> Node171!!95::D4	GNDGRP0	PWRGRP0	D<4>	Z372091_BI7	Non-Inverting	V_in_1	Output
94	<input checked="" type="checkbox"/> 94 <==> Node170!!94::D5	GNDGRP0	PWRGRP0	D<5>	Z372091_BI7	Non-Inverting	V_in_1	Output
93	<input checked="" type="checkbox"/> 93 <==> Node169!!93::D6	GNDGRP0	PWRGRP0	D<6>	Z372091_BI7	Non-Inverting	V_in_1	Output
92	<input checked="" type="checkbox"/> 92 <==> Node168!!92::D7	GNDGRP0	PWRGRP0	D<7>	Z372091_BI7	Non-Inverting	V_in_1	Output
⊥ 2	<input checked="" type="checkbox"/> 2 <==> Node229!!2::GND	GNDGRP0	NC	GND	GND	Non-Inverting		
⊥ 5	<input checked="" type="checkbox"/> 5 <==> Node230!!5::GND	GNDGRP0	NC	GND	GND	Non-Inverting		
⊥ 11	<input checked="" type="checkbox"/> 11 <==> Node231!!11::GND	GNDGRP0	NC	GND	GND	Non-Inverting		

Filter Package Model :  None  Pin RLC  Package Model : model.pkg [ ]

Set On Die Subcircuits...

OK Cancel

- This window shows the necessary setup items for a complete SSO analysis.
- Note the highlighted button that allows assignment of On Die Subcircuits - the EDA tool must allow access to the pullup and pulldown nodes. (Since there is not direct access to these nodes in the IBIS file, the on-die PDS model cannot be embedded in the IBIS file.)
- Special handling is needed at the pin side to lump the PCB terminals to match the .pkg model.

# IBIS Package Model Accuracy

Typical Package Data Net Insertion Loss Curve

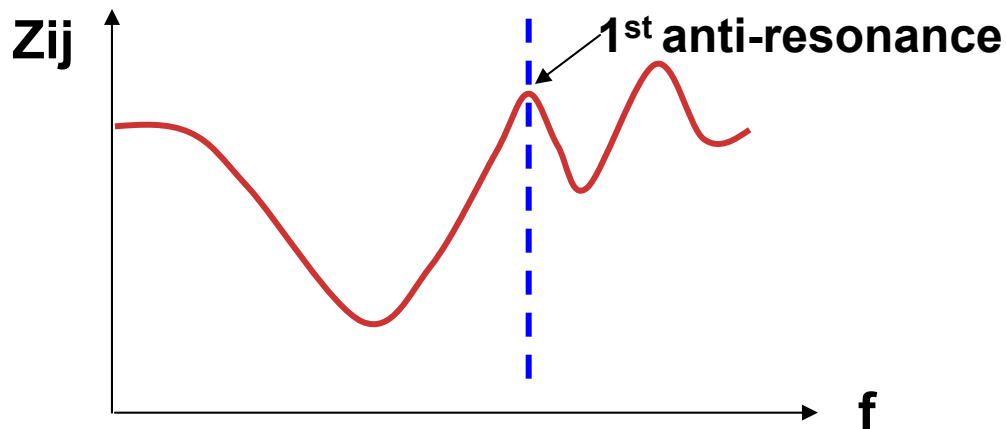
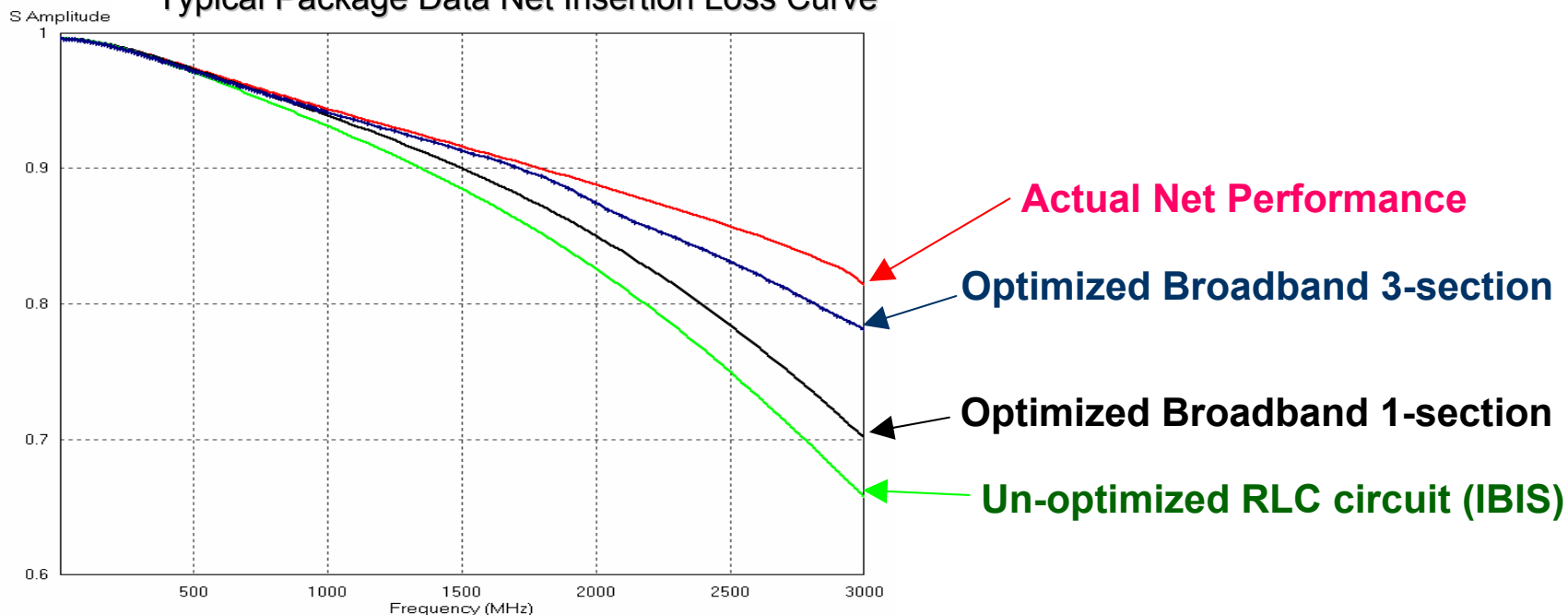

- IBIS PKG models are the least complex but have the least bandwidth
- An IBIS PDS model is generally acceptable to the first unloaded resonance. PKG decaps reduce this.
- Comparison against actual package S-parameters is the best metric.

# Summary

- The IBIS package model specifications contain a number of assumptions and nuances that should be thoroughly understood to build accurate models
- This presentation examined issues and modeling techniques for packages with multiple pad/pin PDS nets and “plane” routing
- The [Pin] Model should be used for ideal-PDS simulations only
  - No RLCs should be present in POWER or GND pins
  - Signal pin RLCs should be loop values – not partials
- [Model Data] matrices can include the coupling necessary to build models for SSO analysis
  - POWER and GND terminals should be lumped to reduce model complexity and avoid potential tool issues with mutual resistance
  - The loop modeling concept should also be utilized in this model
- PDS connectivity at the die and board must be carefully managed
- IBIS package model bandwidth is limited by structure resonances
  - Comparison with actual S-parameter response is recommended

# Acknowledgement of Sigrity Contributors That Made This Presentation Possible

Mr. Brad Brim

Mr. Jack W. C. Lin

Ms. Yinglei Ren

Ms. Tao Xu

Mr. Gang Kang

# References

1. **Fundamentals of S-Parameter Modeling for Power Distribution System (PDS) and SSO Analysis.** IBIS Summit, June 2005.
2. **Issues with Interfacing “2N” and “N+ref” Behavioral Models.** IBIS Summit, June 2005.
3. **System System-Level SSO Simulation Techniques with Various IBIS Package Models.** IBIS Summit, October 2006.
4. Thierauf, Stephen C. **High-Speed Circuit Board Signal Integrity**. Artech House Publishers, 2004. Pages 20-22.

# Thank You!

