

Split C-comp for Quiet Line

Lance Wang / Shangli Wu

September 8, 2005 – IBIS Future

Outline

- C_comps in IBIS
- How do C_comps affect simulations?
- What does HSpice Transistor-Level model give?
- Conclusions

C_comps in IBIS

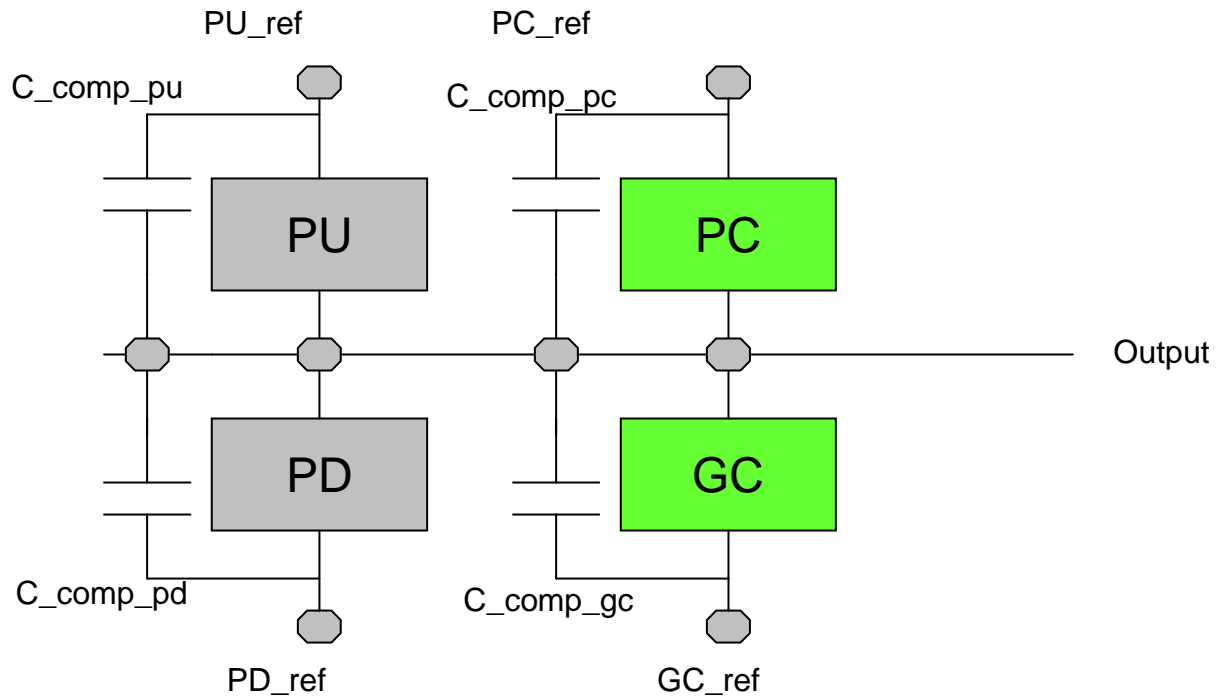

C_comps in IBIS

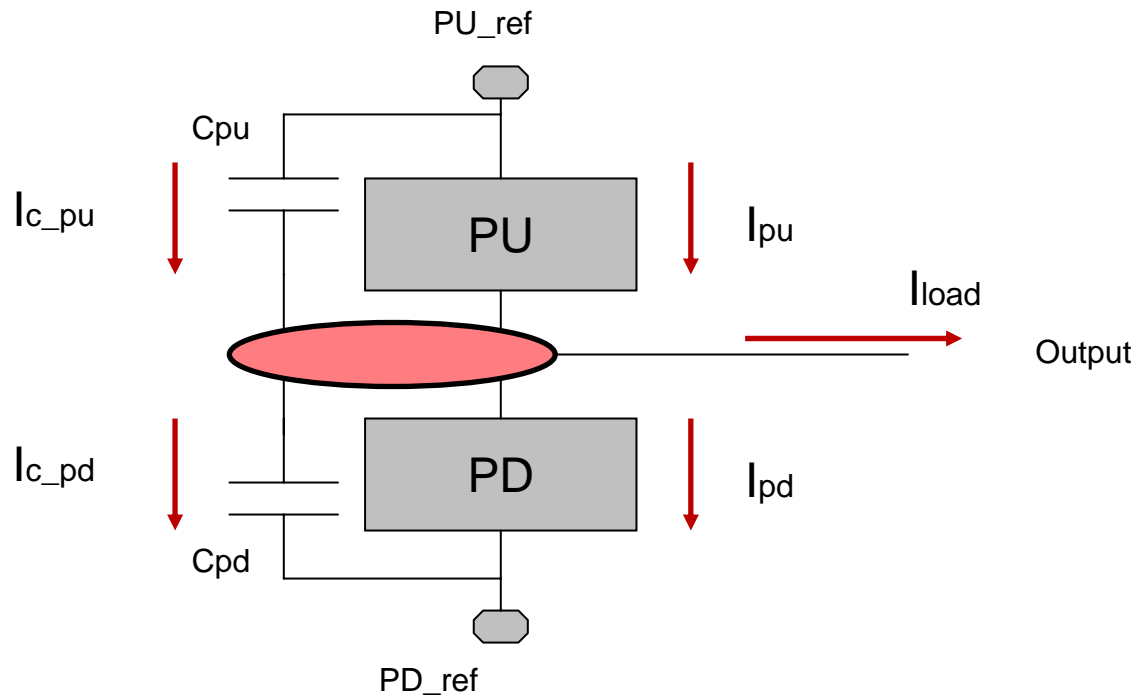

How do C_comps affect simulations?

$$I_{pu} + I_{c_pu} + I_{pd} + I_{c_pd} - I_{load} = 0 \text{ ---- (1)}$$

$$I_{load} = F_{pu} + C_{pu}*(dV_{pu}/dt) + F_{pd} + C_{pd}*(dV_{pd}/dt) \text{ ---- (2)}$$

Where:

F_{pu} is from V/I Pullup

F_{pd} is from V/I Pulldown

$$V_{pu} = V_{pu_ref} - V_{output}$$

$$V_{pd} = V_{output} - V_{pd_ref}$$

From (2):

$$\begin{aligned} I_{load} &= F_{pu} + F_{pd} + C_{pu}*(dV_{pu_ref}/dt - dV_{output}/dt) + C_{pd}*(dV_{output}/dt - dV_{pd_ref}/dt) \\ &= F_{pu} + F_{pd} \\ &\quad + (C_{pu}* dV_{pu_ref}/dt - C_{pd}* dV_{pd_ref}/dt) + (- C_{pu} + C_{pd})*(dV_{output}/dt) \text{ ---- (3)} \end{aligned}$$

From (3) using fixed PU_ref and PD_ref:

$$I_{load} = F_{pu} + F_{pd} + C_{pwr-gnd} + (- C_{pu} + C_{pd})*(dV_{output}/dt) \text{ ---- (4)}$$

$$\text{Where } C_{pwr-gnd} = C_{pu}* dV_{pu_ref}/dt - C_{pd}* dV_{pd_ref}/dt = 0$$

How do C_comps affect simulations?

$$I_{load} = F_{pu} + F_{pd} + (-C_{pu} + C_{pd}) * (dV_{output}/dt) \text{ ---- (4')}$$

When Input State steady (Quiet Line)

I_{load} changes are depended on $(-C_{pu} + C_{pd}) * (dV_{output}/dt)$, So,

$$I_{load} = f((C_{pd} - C_{pu}) * (dV_{output}/dt))$$

The key is $(C_{pd} - C_{pu})$!

What does HSpice Transistor-Level model give?

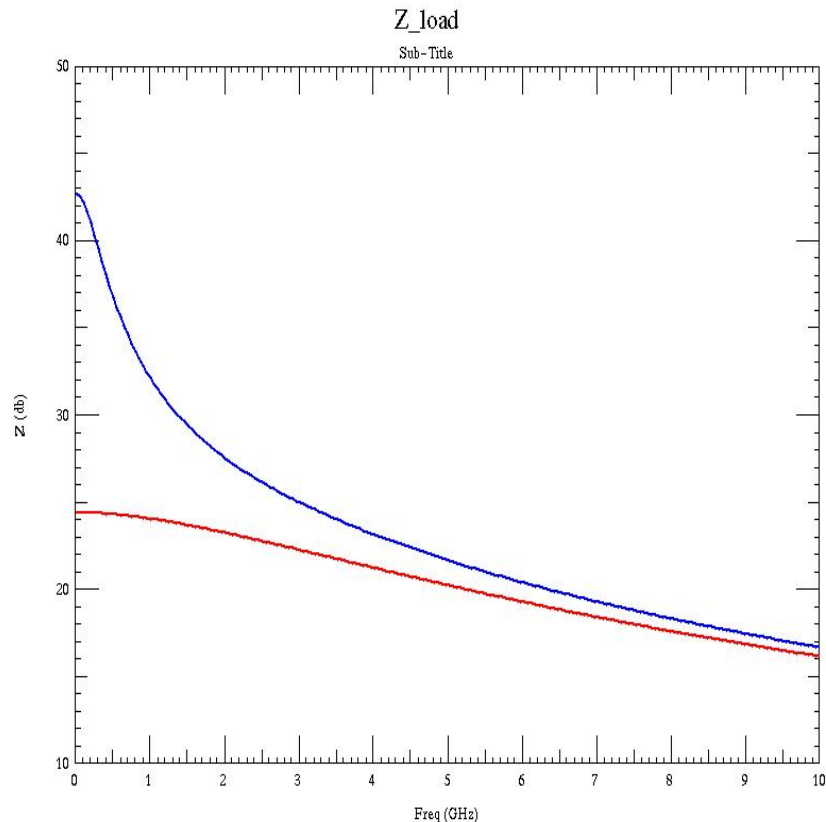
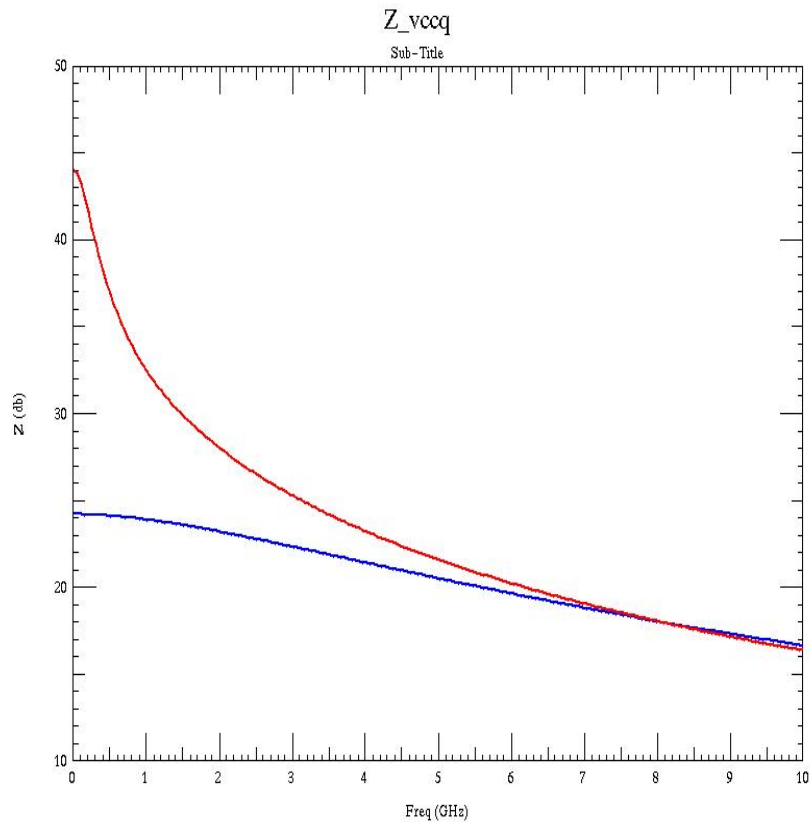

— HSpiceZ_vccq (input HIGH) — HSpiceZ_vccq (input LOW)

— HSpiceZ_load (input HIGH) — HSpiceZ_load (input LOW)

- Used the same Micron Model (u27a_dp) that Cisco used in the last result presentation

Conclusion

- C_comp (PU/PD) ratio is changing when Input-State from Low-High
 - They are almost switched as we showed in last slide
- Simulation should NOT give a correct results for the Quiet lines on both Low and High states if it used a fixed ratio of C-comps!